

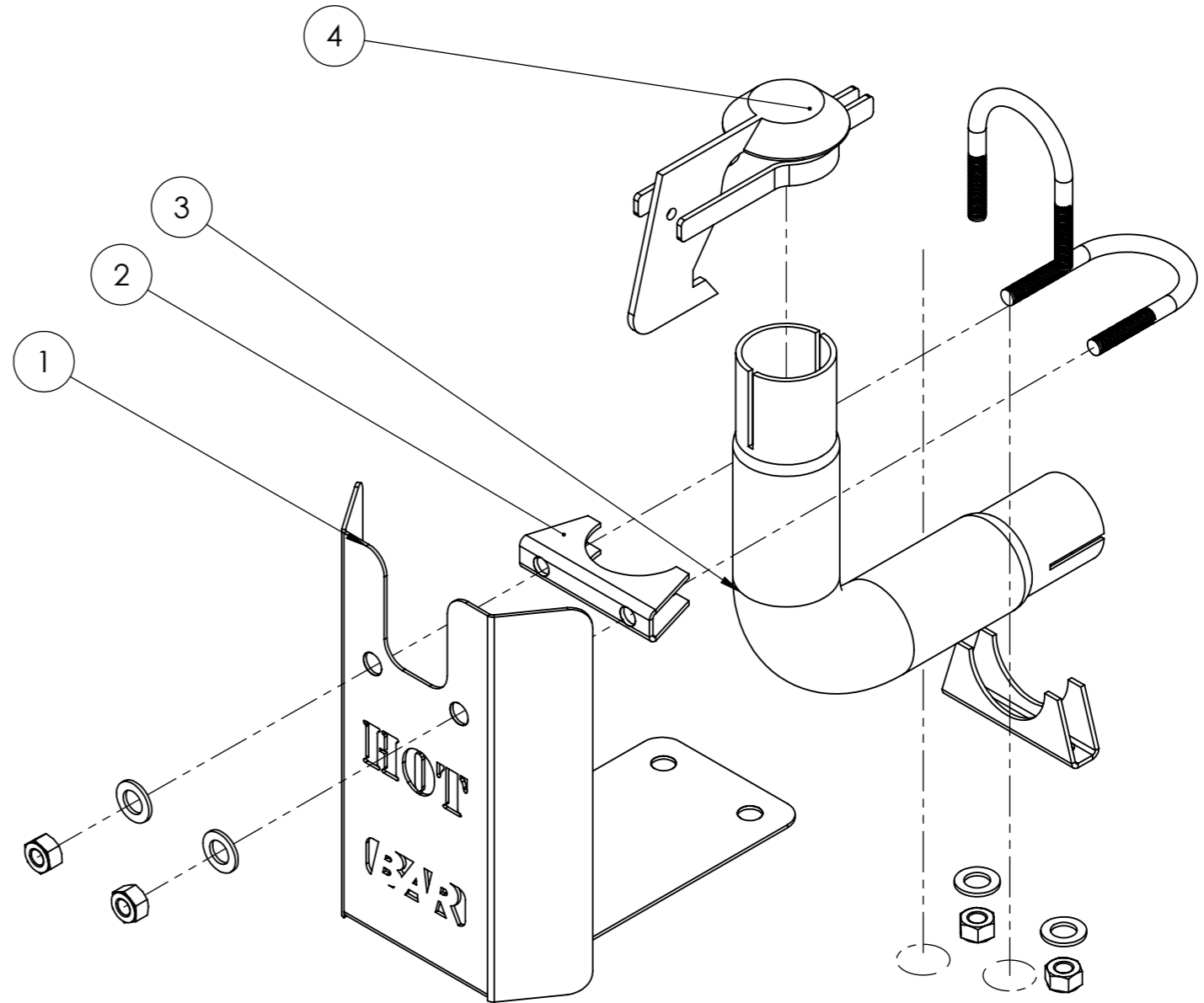

UNLESS OTHERWISE SPECIFIED: DIMENSIONS ARE IN MILLIMETERS SURFACE FINISH: TOLERANCES: LINEAR: ±1mm ANGULAR: ±0.5°				FINISH: Various		DEBURR AND BREAK SHARP EDGES		 B.A.R. Group P/L			
				PART NO. / PRODUCT		125 85.804.502 GA Drawing					
DRAWN Harrison F				SIGNATURE		DATE 06/02/2024		NO		REVISIONS	
CHK'D								NAME		DATE	
APPVD											
MFG											
Q.A								MATERIAL:		DESCRIPTION	
								Various [See BOM]		Kit for Heat Shield and Exhaust (GX690/800)	
								WEIGHT: 1366.10		SCALE: 1:2.5	
										SHEET 2 OF 3	
										A3	

ITEM NO.	PART NUMBER	DESCRIPTION	QTY.
1	125 85.804.501	Heat Shield for Exhaust (GX690/800)	1
2	125 85.804.506	42 mm C Clamp for Exhaust	2
3	125 85.804.507	Bend Exhaust	1
4	125 85.804.535	38mm Rain Cap	1



UNLESS OTHERWISE SPECIFIED: DIMENSIONS ARE IN MILLIMETERS SURFACE FINISH: TOLERANCES: LINEAR: ±1mm ANGULAR: ±0.5°			FINISH: Various		DEBURR AND BREAK SHARP EDGES		 B.A.R. Group P/L						
		NAME		SIGNATURE		DATE		NO		REVISIONS		PART NO. / PRODUCT	
DRAWN		Harrison F				06/02/2024						125 85.804.502 GA Drawing	
CHK'D													
APPVD													
MFG													
Q.A										MATERIAL: Various [See BOM]		DESCRIPTION Kit for Heat Shield and Exhaust (GX690/800)	
										WEIGHT: 1366.10		SCALE: 1:2.5	
												SHEET 3 OF 3	

F
E
D
C
B
A

F
E
D
C
B
A

8

7

6

5

4

3

2

1

8

7

6

5

4

3

2

1