

# BE POWER<sup>®</sup> EQUIPMENT

## Radiant Diesel Heater

Low Noise • Reduced Fumes & Odour  
Thermal Cutout Protection • Thermostat Control

**20.5KW - 70,000BTU - Diesel / Kerosene**



**HK070RD**

**USER MANUAL**

**INDUSTRIAL**

**SERIES**

**QUIET DRIVE**



**CONTENTS**

Contents	3
About This Document	3
Introduction	4
Specifications	4
Equipment Identification	4
Safety Guidelines	5
Assembly Instructions	7
Clearance Requirements	7
Operating Principle	8
Working Environment	8
Operating Instructions	9
Maintenance	10
Troubleshooting / Error Codes	10
Circuit / Wiring Diagram	11
Parts Diagram	12
Parts List	13
Energy Related Products (ErP) Directive Information	14
Limited Warranty Statement	15
Environmental Protection	17
Waste Electrical and Electronic Equipment (WEEE) Statement	17

**ABOUT THIS DOCUMENT**

This manual has been compiled by BAR Group Pty Ltd as an integral part of the product with which it is enclosed and should be kept for future reference. Please read all the information provided in this User Manual before operating the product.

The manual outlines the purpose for which the product has been designed and contains all the necessary information to ensure its proper and safe use. We strongly recommend reading this information before performing any maintenance or repairs. By following the general safety instructions in this manual, you will help ensure operator safety and extend the equipment's lifespan.

All photographs and drawings in this manual are provided by BAR Group Pty Ltd to illustrate the product's operation. While every effort has been made to ensure the accuracy of the information, our policy of continuous improvement grants the right to make modifications without prior notice.

If you have any questions or need additional information about the safe use, operation, maintenance, or repair of this equipment, please contact your nearest BAR Group Pty Ltd representative.

## INTRODUCTION

- The BE HK070RD Radiant Diesel Heater produces 70,000 BTU (20kW) of infrared heat, making it ideal for heating large, well-ventilated spaces such as garages and warehouses.
- It is suitable for use with diesel, kerosene, or paraffin fuel.
- Equipped with a durable 13L steel fuel tank, it offers an economical average fuel consumption of 2.0 liters per hour.
- Features an LED thermostatic control with automatic cut-off, ensuring cost savings through reduced energy and fuel consumption.
- Includes a timed ventilation system to cool the combustion chamber efficiently.
- Designed with tough, powder-coated housing for enhanced protection from the elements and demanding work environments.
- Includes a strong carry handle on top of the heater, a safety grill, a simple on/off switch and an ignition button.

## SPECIFICATIONS

Voltage ~ Frequency:	230V ~ 50Hz
Power:	105W
Power Cable / Plug:	10A AU Style Plug
Heat Output:	70,000 BTU/Hr (20.5kW)
Average Heating Area:	165m <sup>2</sup> /h
Fuel Consumption:	2.0L/Hr
Fuel Type:	Diesel / Kerosene
Fuel Tank Capacity:	13L
Maximum Run Time:	6.5Hrs
Automatic Shut-Off:	Yes
Assembled Dimensions (LXWXH):	576 x 330 x 575mm
Weight:	16.5kg

## EQUIPMENT IDENTIFICATION



## SAFETY GUIDELINES



Please read and ensure that you understand all of the operating instructions, safety precautions and warnings in this Instruction Manual before operating or maintaining this equipment. Save this user manual and keep it with the equipment for future reference. An accident can often be avoided by recognizing a potentially hazardous situation before it occurs, and by observing the appropriate safety procedures.



Never use this equipment or modify it in any way that has not been specifically recommended by the manufacturer. Ensure that the heater is maintained, cleaned and serviced regularly and stored in a suitable environment. Check the equipment for any signs of damage before use. Contact a qualified electrician for advice on any issues relating to electrical safety in your working environment

## GENERAL EQUIPMENT SAFETY

- Always follow basic safety precautions when using your heater to reduce the risks of fire, electric shock, personal injury, and/or damage to the heater.
- Familiarize yourself with the specifications, fuel and electrical supply requirements, equipment controls, warning labels, and operating instructions before use.
- Do not use the heater in damp or wet locations, such as bathrooms, or expose it to rain. (Refer to the clearance guidelines included in this document.)
- Never operate the heater in explosive atmospheres or environments containing flammable liquids, gases, dust, or other combustible substances.
- Keep children, pets, animals, and untrained personnel away from the work area during operation.
- Store the heater in a dry and secure location when not in use.
- Do not modify the machine in any way that could compromise safe operation.
- Keep the work area around the machine clear and free of clutter to prevent accidents and injuries.
- Inspect the equipment and cabling before each use. Do not use the heater if any damage is detected. For repairs or maintenance, contact BAR Group Pty Ltd.
- Only use BE-approved replacement parts to maintain safe equipment use and avoid invalidating the warranty. Repairs should always be carried out by a qualified engineer.
- Do not allow untrained individuals to operate the heater, and never operate it without all covers and housing properly fitted.
- Do not move or handle the heater while it is running or still hot. Always turn it off and allow it to cool before moving it.
- Never leave the heater unattended while in use. Turn it off and unplug it from the mains supply before leaving the work area.
- Ensure that the air inlet (rear) and air outlet (front) of the heater are not obstructed.
- Do not use any form of ducting on the front or rear of the heater.
- Always operate the heater in an upright position on a level surface with sufficient clearance (see page 7 for details).
- Never stand on the heater.



### WARNING:

No responsibility is accepted for incorrect use of this equipment. Incorrect use can result in damage to the equipment and danger to the user. Warranty will be void in the event of incorrect use. The warnings, cautions and instructions discussed in this instruction manual cannot cover all possible conditions and situations that may occur. It must be understood by the operator that common sense and caution are factors which cannot be built into this product, but must be applied by the operator.

## ELECTRICAL SAFETY



Ensure that you check the equipment thoroughly to ensure it is safe and fit for purpose before each use. It is important that you inspect all plugs, sockets, power cables and electrical fittings for wear and damage and repair or replace any defective components. The risk of electric shock can be minimised by the correct use of the appropriate electrical safety devices.

- We recommend that you fit a Residual Current Circuit Breaker (RCCB) in the main distribution board and that a Residual Current Device (RCD) is used when operating this equipment.
- Check that all equipment cables are secure, correctly insulated, free from damage, and protected against short circuit and overload before connecting to the power supply. Do not use worn or damaged cables, plugs, sockets or other fittings.
- Ensure that the power supply matches voltage requirements specified on the equipment and that the plug is wired correctly and fitted with the correct fuse.
- If the electrical fuse blows, ensure it is replaced by an identical type of fuse with the same rating.
- Never pull or manoeuvre this equipment into position using the power cable.
- Ensure the power cable is kept away from heat, oil and sharp edges.
- We recommend that the equipment is connected directly to the power supply without the use of extension leads as the resulting voltage drop can reduce motor performance.
- Always disconnect the equipment from the power source before servicing, inspecting, maintaining, cleaning, replacing or checking any parts.

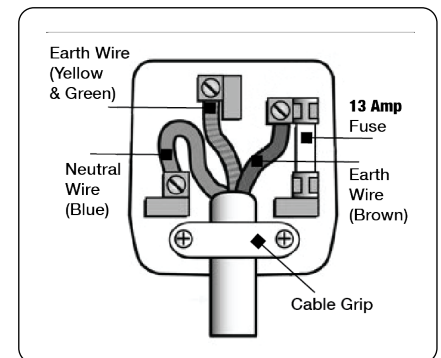

## WORK AREA SAFETY

- Always ensure a sufficient working area, that is clean and tidy, and free access to the machine and peripheral devices.
- Ensure sufficient lighting is available in the working area which will not create shadows or cause a stroboscopic effect.
- Disconnect the heater from the mains supply when not in use.
- Avoid unintentional starting: Make sure the switch is in the "OFF" position before connecting the heater to the mains supply.
- Never carry the heater by the mains lead or pull it to remove the plug from the mains socket. Keep the mains lead away from heat, oil and sharp edges.
- If the mains lead is damaged, it must be replaced by the manufacturer or its service agent or a similarly qualified person in order to avoid unwanted hazards.
- Do not expose the heater to water spray, rain, dripping water or moisture of any kind.
- Do not touch the heater outlet or any internal parts when first switched off as these can be hot and will take time to cool.
- Ensure that the heater is correctly turned off when not in use and stored in a safe, dry area, out of reach of children.
- Do not unplug the heater to switch it off - always use the ON / OFF switch on the control panel and allow the cooling fan to run and automatically stop (after around 3 minutes?) before disconnecting from the mains supply.

**WARNING:** Do not use the heater near flammable material, liquids, solids, gases or compressed gas cylinders. Do not direct the front of the heater towards any combustible materials (e.g. wooden items, cloth, plastics, paper).

## ASSEMBLY INSTRUCTIONS

### FITTING THE HANDLE

1. Attach the handle by lining up the holes in the handle with the holes on the upper shell / housing of heater (see Fig.1).

2. Insert the screws and tighten until secure

### FITTING THE STAND

1. Line up the holes on the stand with the holes on the fuel tank of the heater as shown in (see Fig.2).

2. Fit screws through the holes and secure in place by fitting and tightening the nuts.

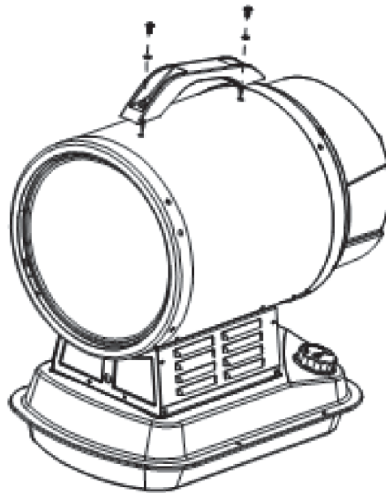

Fig. 1

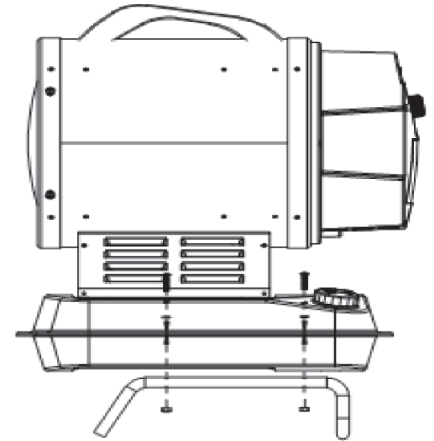

Fig. 2

**PLEASE NOTE:** When using the heater for the first time, you may notice a slight emission of smoke, or a slight burning smell. This is normal and will stop after a short time. Parts of the heater were coated with protection oil during production. The smoke / smell is caused by any small residue of this oil.

## CLEARANCE REQUIREMENTS

Always provide adequate space around the heater as shown in the diagram and table in (Fig.3) below:

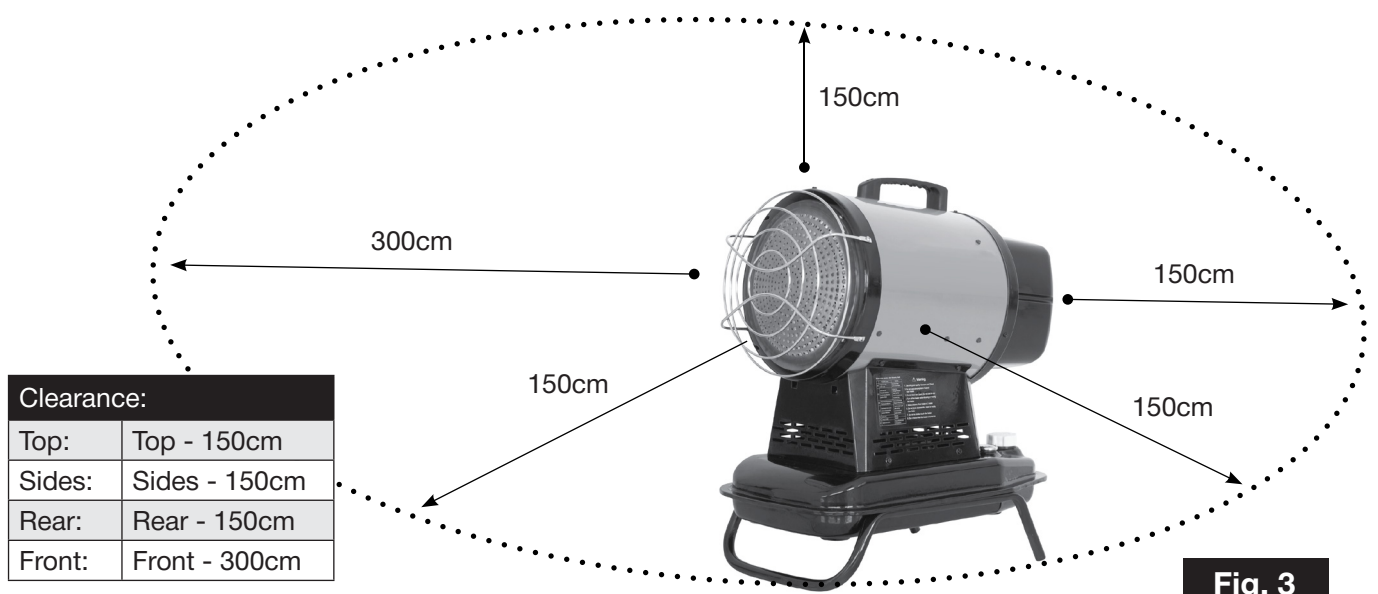

Fig. 3



## OPERATING PRINCIPLE

The BE HK070RD Radiant Diesel Heater produces up to 70,000BTU (20.5kW) of infrared heat, which warms objects rather than the air.

Infrared is the same heat we feel from an environment warmed by the sun and makes this heater an ideal solution for heating large well-ventilated spaces like garages and warehouses.

Airflow is necessary to ensure proper combustion; It is supplied by the internal burner fan. The air enters the burner funnel and gets mixed with a high-pressure fuel jet.

The fuel flow is supplied by an electrical pump, which sucks the fuel from the tank and moves it to the nozzle under high pressure.

The HK070RD heater is fitted with safety cut-outs to protect against overheating and to protect the heater should it tip over.

The heater is also equipped with a clean and efficient burning unit which operates on diesel, kerosene or paraffin.

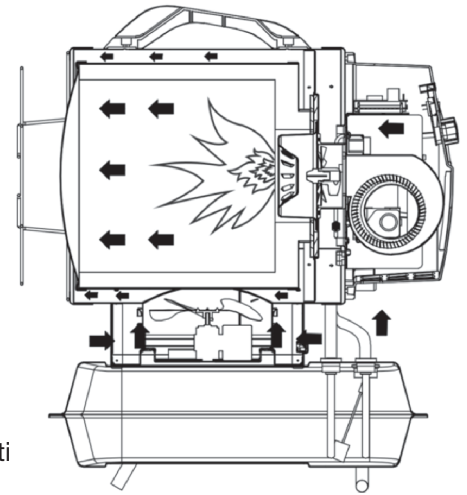

Fig. 4

**WARNING: Do Not Use Petrol or Gasoline Fuel With This Heater!**

## WORKING ENVIRONMENT

### VENTILATION



**WARNING!** Only operate and refuel/fuel the heater in well ventilated areas. Careful consideration must be given to the placement of the heater to provide safe and comfortable heating. Ensure continuous ventilation is provided to the heater operating area. A ventilation opening must run to the outside of the premises in which the heater is to be operated.

**WARNING:** Air contaminants taken into the heater may affect the heat output, damage the heater and may cause health problems.

Example: Body-shop filler dust/paint overspray will damage the motor bearing, clog the filter and compressor and contaminate the combustion chamber causing flame flutter and health hazards.

Please note that any parts damaged by filler dust/paint overspray or similar will not be covered by warranty



## OPERATING INSTRUCTIONS

### STARTING THE HEATER

1. Fill the fuel tank until the fuel gauge points to “F”.
2. Ensure the fuel cap is securely tightened.
3. Plug the mains lead into a suitable power socket and turn the mains switch on.
4. Push the Power switch on the control panel to the “ON” ( I ) position.

**Note:** *The temperature that the thermostat is set to will be shown on the display: If the set temperature is lower than the ambient temperature, the heater will not run and after a few seconds the ambient temperature will show on the display.*

5. To start the heater, turn the thermostat control clockwise to raise the set temperature (as shown on the display) above the ambient temperature and the heater will run. If the set temperature is higher than the ambient temperature the heater will start to run.
6. Once running the ambient temperature will show on the display.

The set temperature can be adjusted at anytime during operation; Turn the thermostat control left to lower the temperature and clockwise to raise the temperature, at this time the temperature on the display indicates the set temperature and after a few seconds it will change to the ambient temperature.

The heater will run until the ambient temperature goes above the set temperature, at which point the heater will automatically stop running until the ambient temperature drops below the set temperature, or the thermostat is turned up.

### STOPPING THE HEATER

1. Turn the power switch to the “OFF” ( 0 ) position.
2. Combustion will stop and the cooling cycle will begin.
3. When cooling cycle has been completed and the fan stops running (approximately 3 minutes), it is safe to turn off and unplug the heater at the mains supply.



**WARNING!** Do not turn the mains switch off or disconnect the heater from the mains supply to stop the heater or until the cooling cycle is complete. Turning the mains switch off, or removing the plug from the mains supply to stop the heater or before the cooling cycle is complete may cause overheating, possible damage to the heater and will void the warranty.

## MAINTENANCE

Component:	Frequency:	Procedure:
Fuel Tank	Clean every 150-200 hours of operation or when necessary	Empty and rinse with fresh fuel.
Nozzle	Clean or replace once per season or when necessary	Contact BAR Group Pty Ltd.
Photocell	Clean once per season or when necessary	Contact BAR Group Pty Ltd.
Fuel Filter	Clean or replace twice per season or when necessary	Clean the fuel filter with clean fuel.
Ignition Device	Clean or replace every 1000 hours of operation, or when necessary	Contact BAR Group Pty Ltd.
Fan Blades	Clean when necessary	Contact BAR Group Pty Ltd.

## TROUBLESHOOTING / ERROR CODES

ERROR CODE	CAUSE	SOLUTION
<b>E0</b>	<b>Operator Error:</b>	
	1. The power switch is in the "ON" ( I ) position when the heater is connected to the mains supply.	1. Disconnect the heater from the mains supply, turn the power switch to the OFF position and reconnect to the mains supply.
<b>E1</b>	<b>Photocell Error:</b>	
	1. No fuel in tank. 2. Fuel is contaminated / dirty. 3. Fuel filter is dirty / blocked. 4. Photocell is dirty or faulty. 5. Ignition error.	1. Turn the power switch "OFF" and refuel the heater. 2. Turn the power switch "OFF" and drain the fuel tank; Clean or replace the fuel filter and refill the tank with clean fuel. 3. Clean or replace the fuel filter 4. Contact service centre
<b>E2</b>	<b>Temperature Control Sensor Error:</b>	
	1. Cable fallen off or damaged. 2. Sensor faulty / damaged. 3. Ambient temperature above 60°C	1. Contact service centre. 2. Contact service centre. 3. Normal (see page 9 "Starting the Heater).
<b>E3</b>	<b>Thermostat Error:</b>	
	1. Heaters internal temperature is too high 2. Anti-tilt sensor activated	1. Turn the heater off and allow it to cool, then restart. 2. Set the heater on a firm surface, and restart
<b>E4</b>	<b>Blower Motor Error:</b>	
	1. Power cable not connected properly or damaged	2. Contact service centre
<b>E5</b>	<b>Cooling Motor Error:</b>	
	1. Power cable not connected properly or damaged	2. Contact service centre
<b>Hi</b>	1. Ambient temperature below 59°C	1 Normal (see page 9 "Starting the Heater).
<b>LO</b>	1. Ambient temperature below - 9°C	1 Normal (see page 9 "Starting the Heater).
<b>CH</b>	1. Continuous operation 55°C	1. Normal

## CIRCUIT WIRING DIAGRAM

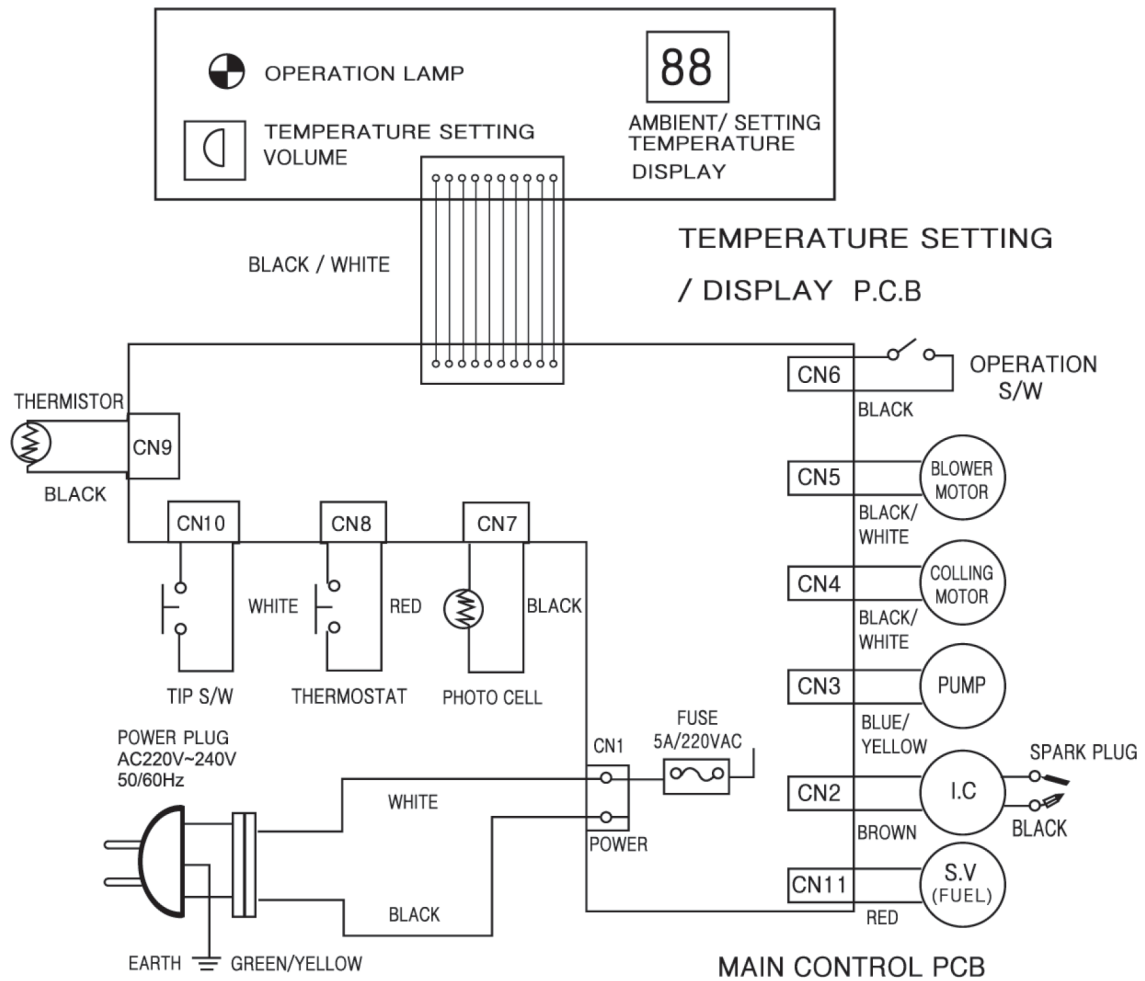

## PARTS DIAGRAM

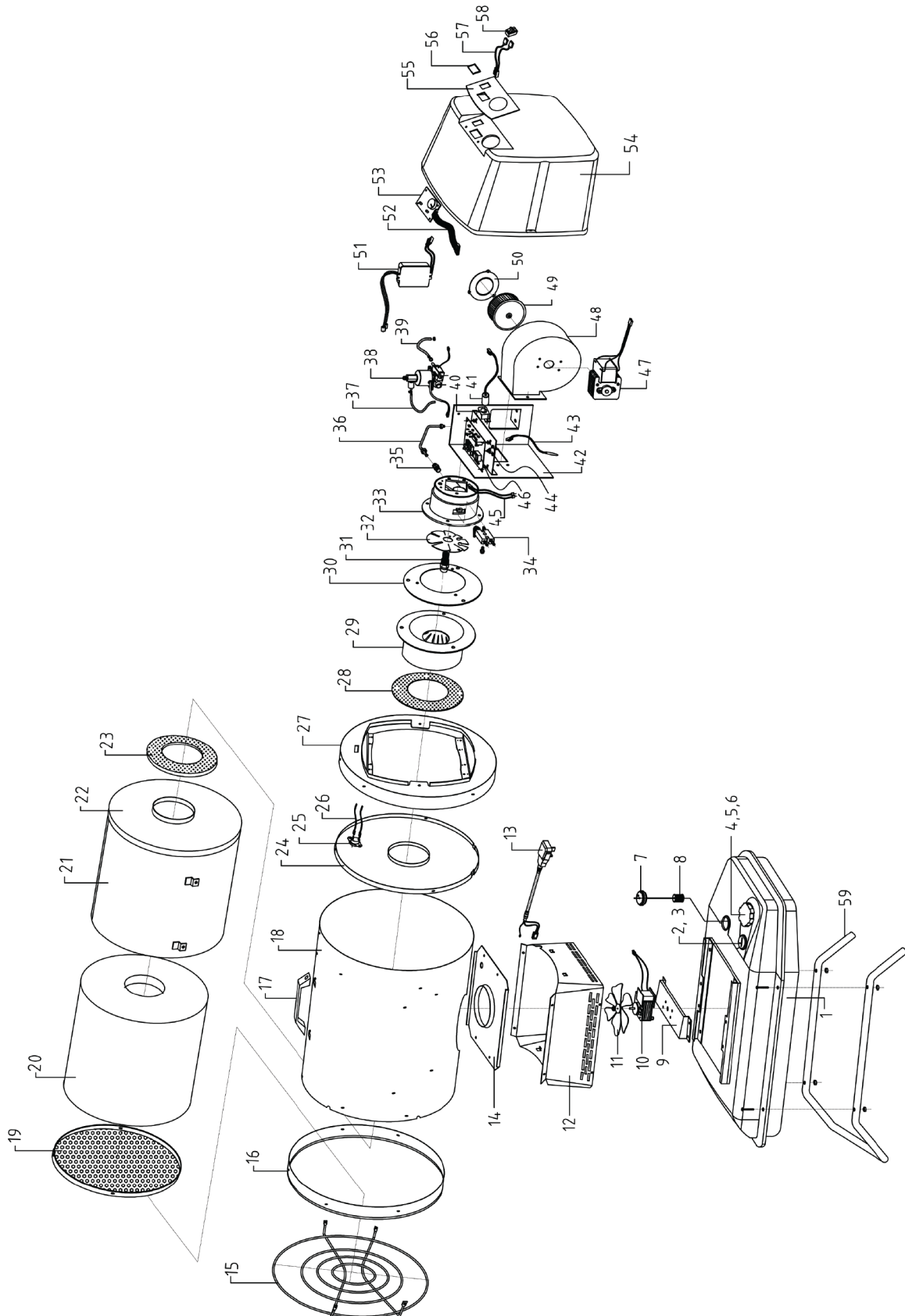

## PARTS LIST

#	DESCRIPTION	#	DESCRIPTION
1.	Fuel Tank	30.	Insulator Plate
2.	Fuel Gauge	31.	Nozzle
3.	Fuel Gauge Seal	32.	Burner Head Blade
4.	Fuel Cap	33.	Burner Head
5.	Fuel Cap Seal (outer)	34.	Electrode
5-1.	Fuel Cap Seal (inner)	35.	Nipple
6.	Fuel Filter	36.	Electronic Pump Pipe
7.	Pumping Filter Seal	37.	PVC Return Hose
8.	Pumping Filter	38.	Electric Pump
9.	Cooling Motor Base	39.	Fuel Hose
10.	Cooling Motor	40.	Photocell
11.	Cooling Fan	41.	Photocell Bracket
12.	Support	42.	Control Base
13.	Mains Lead	43.	Thermistor
14.	Air Outlet Plate	44.	Tilt Switch Wire
15.	Front Guard	45.	Tilt Switch
16.	Cover Ring	46.	PCB
17.	Handle	47.	Blower Motor
18.	Main Cover	48.	Blower Casting
19.	Heating Plate	49.	Blower Fan
20.	Insulator	50.	Inlet
21.	Inner Body	51.	Igniter
22.	Inner Body Cover	52.	Sub PCB Wire
23.	Inner Body Gasket	53.	Sub PCB
24.	Air Guard	54.	Rear Cover
25.	Thermostat	55.	Label
26.	Thermostat Wire	56.	Display Window
27.	Rear Plate	57.	Main Switch Cable
28.	Burner Gasket	58.	On/Off Switch
29.	Diffuser	59.	Stand

### ENERGY RELATED PRODUCT (ErP) DIRECTIVE INFORMATION

<b>Model:</b>	PIN HK070RD - Radiant Diesel Heater		
<b>Indirect Heating Functionality:</b>	No		
<b>Direct Heat Output:</b>	70,000BTU / 20.5kW		
<b>Fuel:</b>	Diesel / Kerosene		Space Heating Emissions:
			Nox
<b>Select Fuel Type:</b>	Liquid		46mg/kWhinput (GCV)

Item	Symbol	Value	Unit	Item	Symbol	Value	Unit
<b>Heat Output</b>				<b>Useful Efficiency (NCV)</b>			
Nominal heat output	Pnom	20.3	kW	Useful efficiency at nominal heat output	$\eta_{th,nom}$	92.6	%
Minimum heat output (indicative)	Pmin	N/A	kW	Useful efficiency at minimum heat output (indicative)	$\eta_{th,min}$	N/A	%
<b>Auxiliary electricity consumption</b>				<b>Type of heat output/room temperature control (select one)</b>			
At nominal heat output	elmax	0.115	kW	single stage heat output, no room temperature control			No
At minimum heat output	elmin	0.115	kW	two or more manual stages, no room temperature control			No
In standby mode	elSB	N/A	kW	with mechanic thermostat room temperature control			No
				with electronic room temperature control			Yes
				with electronic room temperature control plus day timer			No
				with electronic room temperature control plus week timer			No
				other control options (multiple selections possible)			No
				room temperature control, with presence detection			No
				room temperature control, with open window detection			No
				with distance control option			No
				with adaptive start control			No
				with working time limitation			No
				with black bulb sensor			No
<b>Permanent pilot flame power requirement</b>							
Pilot flame power requirement (if applicable)	Ppilot	N/A	kW				
<b>Contact Details</b>				<p><b>BAR Group Pty Ltd</b> 15 Hudson Place, Mulgrave NSW</p> <p><b>Tel:</b> +61 (02) 4577 2144 <b>Email:</b> sales@bargroup.com.au</p> <p><b>Website:</b> www.bargroup.com.au</p>			

## LIMITED WARRANTY STATEMENT

BAR Group Pty Ltd (hereafter referred to as "BAR Group") warrants its customers that its products will be free from defects in workmanship or materials. Upon suitable notification, BAR Group will correct any defects by repairing or replacing any parts or components of the product determined to be faulty or defective.

This warranty will be considered void if the equipment has been subjected to improper installation, storage, alteration, abnormal operations, improper care, service, or repair

### Warranty Period

BAR Group will cover both the parts and labour expenses required to correct defects during the specified warranty periods outlined below.

All warranty periods commence from the date of purchase from an authorized BAR Group dealer. If the end user cannot provide proof of purchase, the date of purchase will be assumed to be three months after the initial sale to the distributor.

#### 1 Year

PIN HK070RD - 70,000 BTU Radiant Diesel Heater

#### 90 Days

All replacement parts purchased outside of warranty period

**Important:** All parts used in the repair or replacement of warranty-covered equipment will be covered for a minimum of 90 days or for the remainder of the original warranty period, whichever is longer, starting from the original date of purchase.

### Warranty Repair

Should BAR Group confirm the existence of a defect covered under this warranty, the defect will be addressed through repair or replacement by BAR Group.

### Packaging & Freight Costs

The Customer is responsible for packaging and returning the equipment to Bar Group for assessment.

After inspection, if no defect is found or if the equipment is determined not to be covered under the BAR Group warranty terms, the customer will be responsible for any labour and return transportation costs incurred. These costs will be discussed and agreed upon with the customer before the equipment is returned.

\* BAR Group reserve the right to void any warranty for damages identified as being caused through misuse

### Warranty Limitations

BAR Group will not accept responsibility or liability for repairs carried out by unauthorized technicians or engineers. BAR Group's liability under this warranty is limited to the cost of correcting defects in BE products.

BAR Group will not be liable for any incidental or consequential damages (such as loss of business or the hire of substitute equipment) resulting from the defect or the time required to correct it. This written warranty is the sole express warranty provided by BAR Group for its products.

Any implied warranties of merchantability are limited to the duration of this limited warranty for the equipment in question.

BAR Group assumes no responsibility for cable wear due to flexing or abrasion. The end user is responsible for routinely inspecting cables for potential wear and addressing any issues before cable failure occurs.



### Claiming Warranty Coverage

The end user must contact BAR Group Pty Ltd +61 (02) 4577 2144 (AU).

#### Step 1 - Reporting the Defect

Contact BAR Group Pty Ltd or sales representative with the following information:

- Model number
- Serial number (usually located on the specification plate)
- Date of purchase

Contact BAR Group on +61 (02) 4577 2144 for instructions on how to return the equipment for assessment.

#### Step 2 - Returning the Equipment

It is the customer's responsibility to ensure that the equipment is securely and appropriately packaged for collection, along with a copy of the original proof of purchase. Please note that BAR Group cannot accept responsibility for any damage to the equipment incurred during transit. Any claims related to damage caused by third-party couriers will be handled in accordance with the terms and conditions outlined in their road haulage association directives.

**NOTE:** BAR Group will be unable to process any warranty requests without a copy of the original proof of purchase.

#### Step 3 - Assessment and Repair

Upon receipt, the equipment will be assessed by an authorized BAR Group engineer to determine whether it is defective, in need of repair, and covered under the warranty policy. To qualify for warranty coverage, all equipment must have been used, serviced, and maintained as specified in the user manual.

If the repair is not covered under the warranty, a quotation for the repair, including labour costs and return delivery, will be provided to the customer (typically within 7 working days).

**NOTE:** If the repair quotation is not accepted, BAR Group will invoice for 1 hour of labour at \$100 + GST per hour, in addition to return carriage costs (plus GST).

In cases where no fault can be found with the equipment, or, if incorrect operation of the equipment is identified as the cause of the problem, a minimum of 1 hour labour at \$100 + GST per hour plus carriage costs will be required before the equipment will be despatched back to the customer.

Any equipment repaired or replaced under warranty will normally be ready for shipment back to the customer within 7 working days upon receipt of the equipment at an authorised BAR Group Pty Ltd Repair centre (subject to part availability). Where parts are not immediately available BAR Group Pty Ltd will contact you with a revised date for completion of the repair.

### General Warranty Enquiries

For any further information relating to BAR Group warranty cover please call +61 (02) 4577 2144 (AU) or send your enquiry via email to [sales@bargroup.com.au](mailto:sales@bargroup.com.au)

#### Disclaimer:

The information provided in this document is, to the best of our knowledge, true and accurate. However, all recommendations and suggestions are made without guarantee. Since conditions of use are beyond our control, BAR Group Pty Ltd disclaims any liability for loss or damage arising from the use of this data or suggestions.

Furthermore, no liability will be accepted if the use of any product, in accordance with this data or suggestions, infringes upon any patent. BAR Group Pty Ltd reserves the right to modify product specifications and warranty statements without prior notice. All images included are for illustrative purposes only.

## ENVIRONMENTAL PROTECTION



**PLEASE  
RECYCLE**

Recycle any packaging and unwanted materials responsibly, rather than disposing of them as waste. All tools, accessories, and packaging should be sorted, taken to a recycling centre, and disposed of in an environmentally friendly manner.

When the product becomes unserviceable or reaches the end of its working life, ensure that any fluids (if applicable) are drained into approved containers. Dispose of the product and its fluids in accordance with local regulations.

## WASTE ELECTRICAL AND ELECTRONIC EQUIPMENT (WEEE) STATEMENT



Information on Disposal for Users of Waste Electrical & Electronic Equipment

The symbol on the product(s) and accompanying documents indicates that used electrical and electronic products should not be disposed of with general household waste.

For proper treatment, recovery, and recycling, please take the product(s) to designated collection points, where they will be accepted free of charge.

Dispose of this product at the end of its working life in compliance with the Waste Electrical and Electronic Equipment (WEEE) regulations. For recycling information regarding this equipment, contact your local solid waste authority. Proper disposal of this product helps conserve valuable resources and prevents potential negative effects on human health and the environment, which could result from inappropriate waste handling.

Please contact your local authority for details on your nearest designated collection point. Penalties may apply for the incorrect disposal of this waste, in accordance with your national legislation.



When units arrive, after following start

Part No.	Description	Quantity
01	Diaphragm	1
02	Diaphragm gasket	1
03	Diaphragm nut	1
04	Diaphragm washer	1
05	Diaphragm seal	1
06	Diaphragm spring	1
07	Diaphragm pin	1
08	Diaphragm clip	1
09	Diaphragm screw	1
10	Diaphragm bolt	1
11	Diaphragm nut	1
12	Diaphragm washer	1
13	Diaphragm seal	1
14	Diaphragm spring	1
15	Diaphragm pin	1
16	Diaphragm clip	1
17	Diaphragm screw	1
18	Diaphragm bolt	1
19	Diaphragm nut	1
20	Diaphragm washer	1
21	Diaphragm seal	1
22	Diaphragm spring	1
23	Diaphragm pin	1
24	Diaphragm clip	1
25	Diaphragm screw	1
26	Diaphragm bolt	1
27	Diaphragm nut	1
28	Diaphragm washer	1
29	Diaphragm seal	1
30	Diaphragm spring	1
31	Diaphragm pin	1
32	Diaphragm clip	1
33	Diaphragm screw	1
34	Diaphragm bolt	1
35	Diaphragm nut	1
36	Diaphragm washer	1
37	Diaphragm seal	1
38	Diaphragm spring	1
39	Diaphragm pin	1
40	Diaphragm clip	1
41	Diaphragm screw	1
42	Diaphragm bolt	1
43	Diaphragm nut	1
44	Diaphragm washer	1
45	Diaphragm seal	1
46	Diaphragm spring	1
47	Diaphragm pin	1
48	Diaphragm clip	1
49	Diaphragm screw	1
50	Diaphragm bolt	1
51	Diaphragm nut	1
52	Diaphragm washer	1
53	Diaphragm seal	1
54	Diaphragm spring	1
55	Diaphragm pin	1
56	Diaphragm clip	1
57	Diaphragm screw	1
58	Diaphragm bolt	1
59	Diaphragm nut	1
60	Diaphragm washer	1
61	Diaphragm seal	1
62	Diaphragm spring	1
63	Diaphragm pin	1
64	Diaphragm clip	1
65	Diaphragm screw	1
66	Diaphragm bolt	1
67	Diaphragm nut	1
68	Diaphragm washer	1
69	Diaphragm seal	1
70	Diaphragm spring	1
71	Diaphragm pin	1
72	Diaphragm clip	1
73	Diaphragm screw	1
74	Diaphragm bolt	1
75	Diaphragm nut	1
76	Diaphragm washer	1
77	Diaphragm seal	1
78	Diaphragm spring	1
79	Diaphragm pin	1
80	Diaphragm clip	1
81	Diaphragm screw	1
82	Diaphragm bolt	1
83	Diaphragm nut	1
84	Diaphragm washer	1
85	Diaphragm seal	1
86	Diaphragm spring	1
87	Diaphragm pin	1
88	Diaphragm clip	1
89	Diaphragm screw	1
90	Diaphragm bolt	1
91	Diaphragm nut	1
92	Diaphragm washer	1
93	Diaphragm seal	1
94	Diaphragm spring	1
95	Diaphragm pin	1
96	Diaphragm clip	1
97	Diaphragm screw	1
98	Diaphragm bolt	1
99	Diaphragm nut	1
100	Diaphragm washer	1

**Warning**

1. Use only good quality kerosene and Diesel
2. Do not place any explosive material near heater
3. Do not block the guard. Do not use the heater
4. Turn off the heater when refuelling or moving the heater
5. Safety distance from heater is 3 meter
6. Do not try to disassemble, repair or modify the heater
7. Do not let children touch the heater
8. Do it move when the heater is turned on



## **IMPORTANT! SAFETY FIRST!**

Before attempting to use this product please read all the safety precautions and operating instructions outlined in this manual to reduce the risk of fire, electric shock or personal injury.

BAR Group Pty Ltd  
15 Hudson Place, Mulgrave NSW 2756

Tel: +61 (02) 4577 2144  
Email: [sales@bargroup.com.au](mailto:sales@bargroup.com.au)

[www.bargroup.com.au](http://www.bargroup.com.au)